

T = 3", 4"

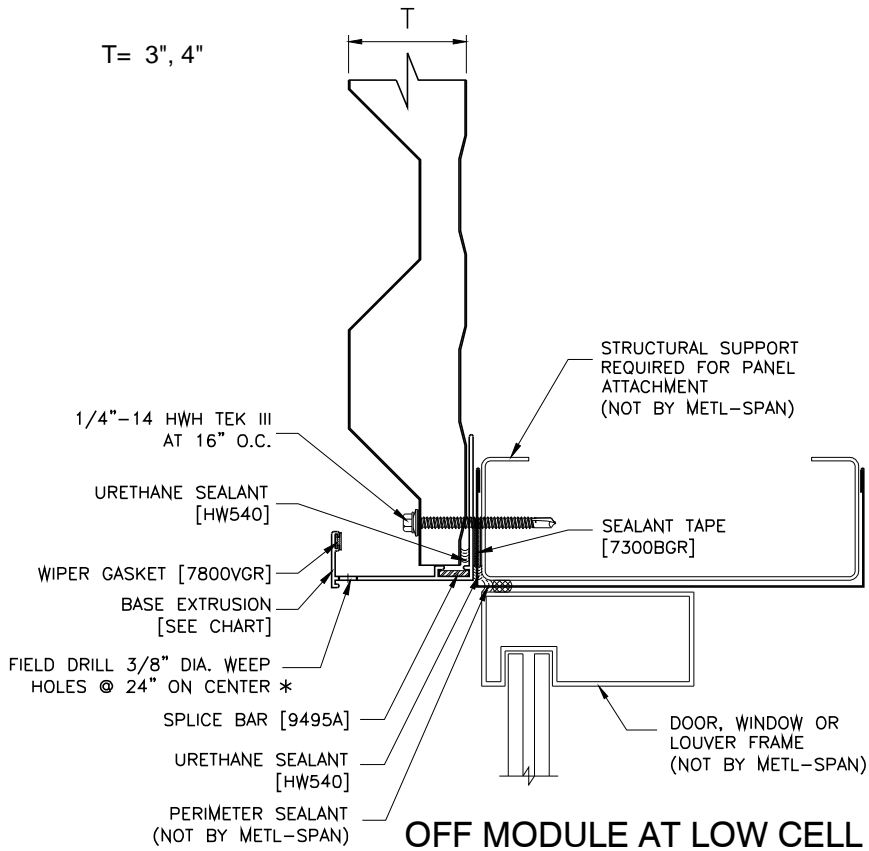

OFF MODULE AT LOW CELL

T = 3", 4"

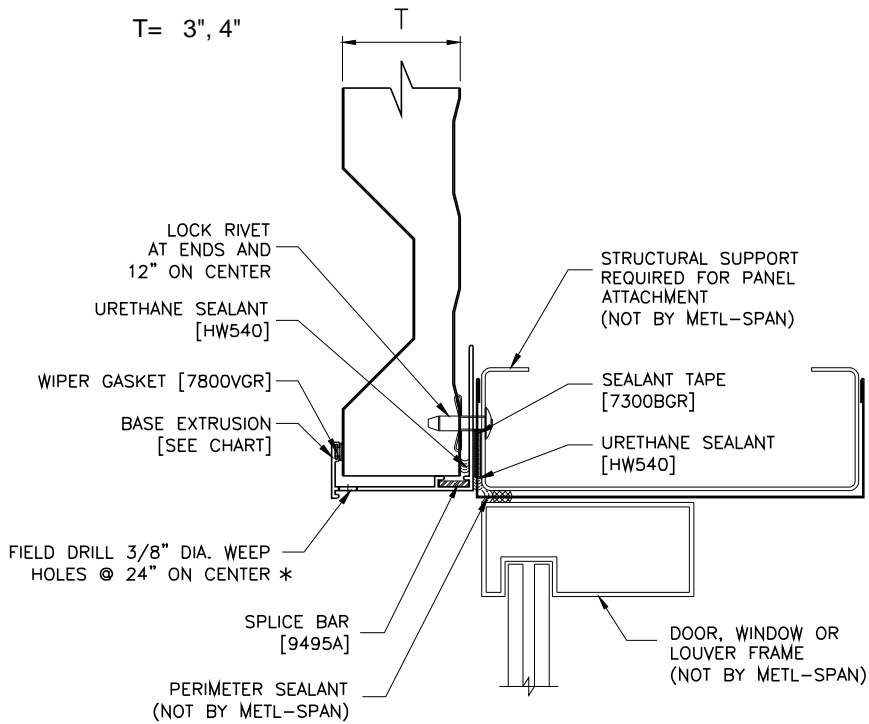

OFF MODULE AT HIGH CELL

* WEEP HOLES TO BE LOCATED NEAR JAMBS OF DOORS.

REFER TO SHEET "CI-INFO" FOR ADDITIONAL INFORMATION REGARDING THE APPLICATION OF SEALANTS, FASTENERS, AND CLOSURE MATERIALS. CONSULT METL-SPAN TO DETERMINE ALLOWABLE LOAD AND SPACING OF ATTACHMENT FASTENERS.

T	BASE EXTRUSION
3"	9407ANC
4"	9404ANC

7.2 INSUL-RIB OFF MODULE HEAD DETAIL WITH EXTRUSION

HORIZONTAL APPLICATION: COMMERCIAL & INDUSTRIAL

© 2016 Metl-Scan, an NCI Building Systems company. All rights reserved.

7.2H-HD-04

DATE: Nov. 9, 2016