

(SPACE ABOVE CEILING MUST BE VENTILATED.)

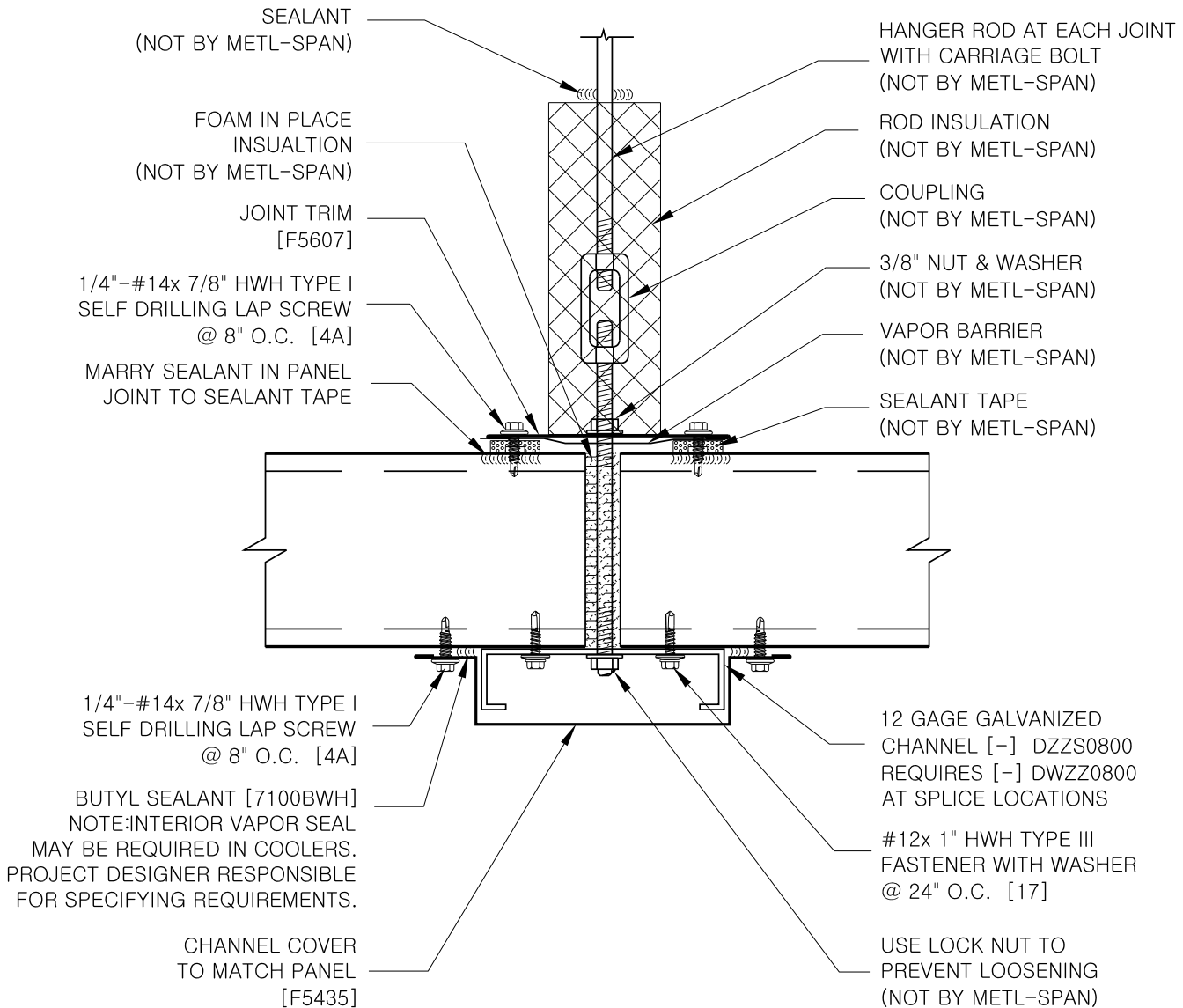

NOTE: BRACING OF ROD MAY BE REQUIRED. DESIGNED AND SUPPLIED BY OTHERS.

NOTE: ALL CEILING SUPPORT COMPONENTS AND PANELS MUST BE INSTALLED COMPLETE PRIOR TO ALLOWING ANY TRAFFIC ON CEILING.

NOTE: REFER TO SHEET "CS-INFO" FOR ADDITIONAL INFORMATION REGARDING THE APPLICATION OF SEALANTS, FASTENERS AND CLOSURE MATERIALS. CONSULT METL-SPAN TO DETERMINE ALLOWABLE LOAD AND SPACING OF ATTACHMENT.