

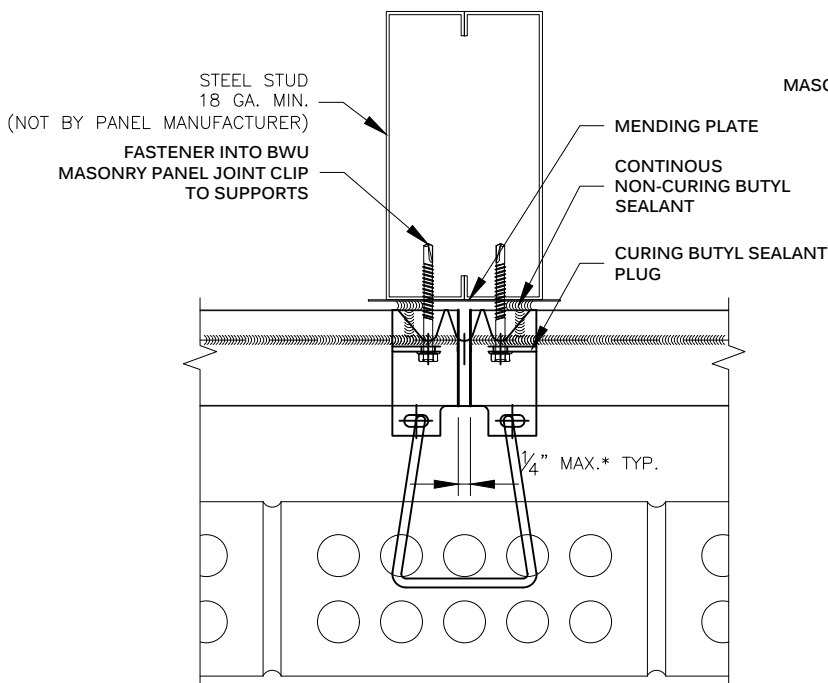

METL SPAN®

INSULATED METAL PANELS

NOTE:
THESE DETAILS ARE FOR INSTALLATION AND SEALING OF BW UNIVERSAL SYSTEM PANELS ONLY. FOR INSTALLATION AND SEALING REQUIRED FOR CLADDING, SEE STANDARD DETAILS FOR SPECIFIC CLADDING.



**VERTICAL JOINT
@ DOUBLE STUD**

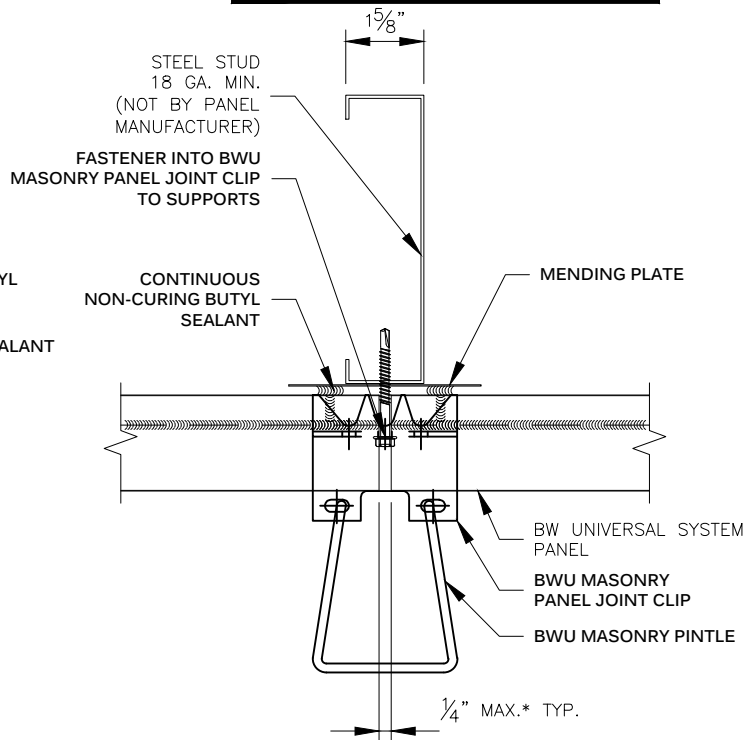

**VERTICAL JOINT
@ SINGLE STUD**

APPLY 3/8" Ø BEAD OF NON-CURING BUTYL SEALANT OVER PANEL LINER MALE LEG AS SHOWN. THIS "MARRIAGE BEAD" WILL CONNECT TO THE FACTORY APPLIED NON-CURING BUTYL SEALANT IN THE SIDE JOINT OF THE PANE ABOVE TO THE FIELD APPLIED BUTYL OF THE MENDING PLATE AT THE PANEL ENDS.

APPLY (2) 3/8" Ø BEADS OF NON-CURING BUTYL SEALANT TO MENDING PLATE AT PANEL ENDS, JOINTS, PERIMETERS AND CUT EDGES.

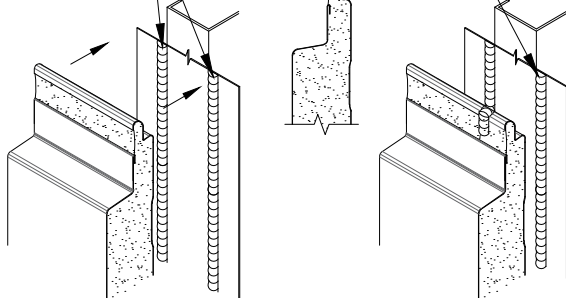

**THE VERTICAL JOINT SEALANT
AND MARRIAGE BEAD**

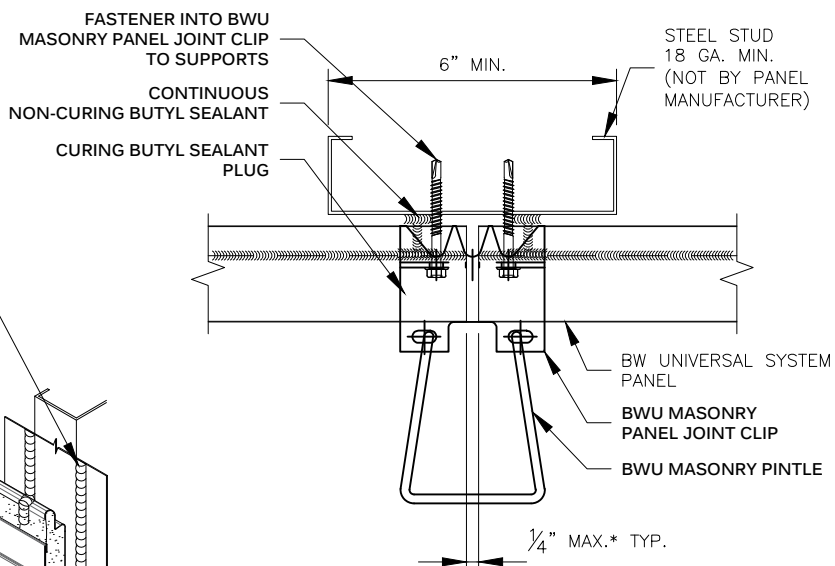

**VERTICAL JOINT
NOT @ STUD**

NOTE:
IF VERTICAL JOINT GAP EXCEEDS 1/4" FILL WITH LOW EXPANSION FOAM.

PANEL ENDS CAN BE LOCATED OFF THE STANDARD 16" OR 24" STUD SPACING. IN THIS CASE THE WIRE HOOK TIE IS NOT REQUIRED.

**MASONRY PANEL JOINT CLIP
VERTICAL JOINT
BW UNIVERSAL SYSTEM™**

DRAWING NO:

BWU-MAS-VJ-01

DATE:

Feb '20

REV:

00