

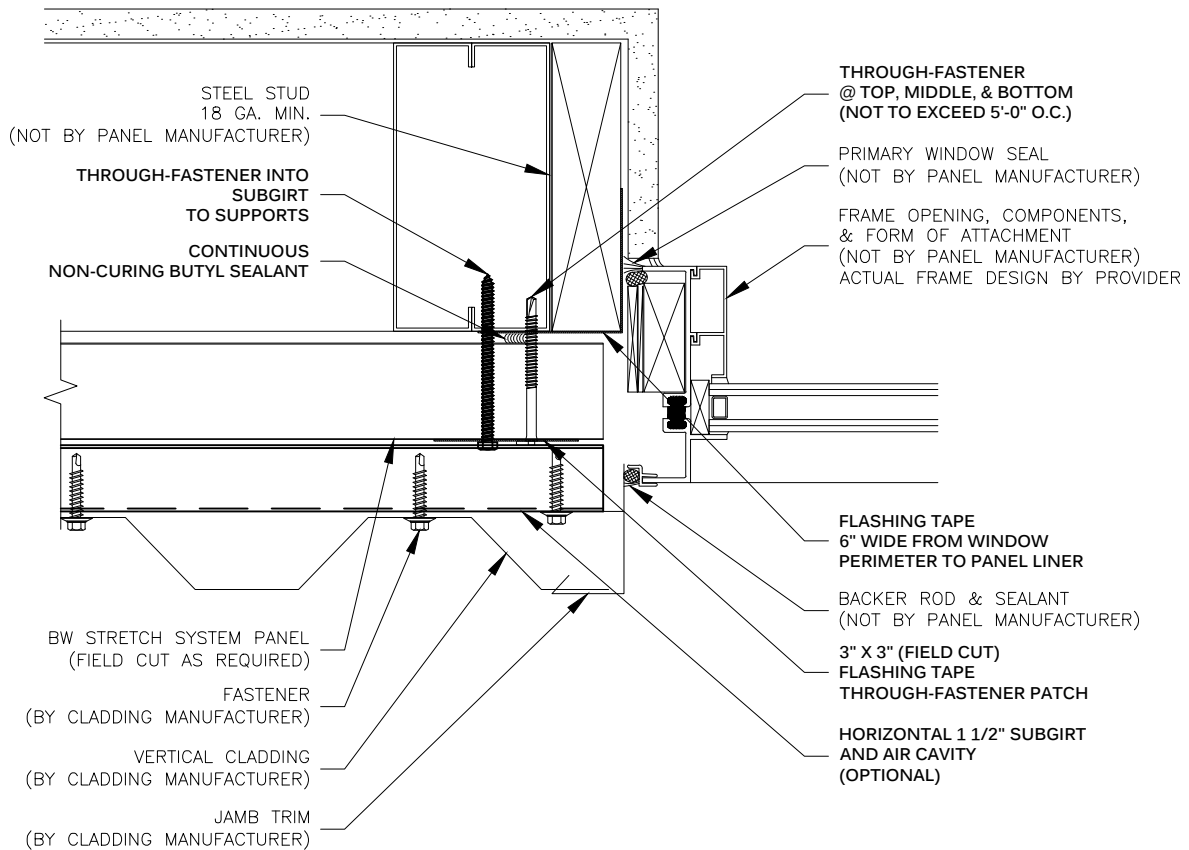

**METL-SPAN®**  
INSULATED METAL PANELS

**NOTE:**  
THESE DETAILS ARE FOR INSTALLATION AND SEALING OF BW UNIVERSAL SYSTEM PANELS ONLY. FOR INSTALLATION AND SEALING REQUIRED FOR CLADDING, SEE STANDARD DETAILS FOR SPECIFIC CLADDING.

\*EQUAL SPACINGS TO BE 12" MIN./24" MAX. FINAL SPACINGS PER WIND LOAD REQUIREMENTS. CONTACT METL-SPAN'S ENGINEERING DEPARTMENT.



**VERTICAL PANEL JOINT CLIP  
JAMB - w/ HORIZONTAL SUBGIRT  
BW STRETCH SYSTEM™**

DRAWING NO:

**BWS-VPJC-HS-JB-01**

DATE:

**Mar '20**

REV:

**00**