

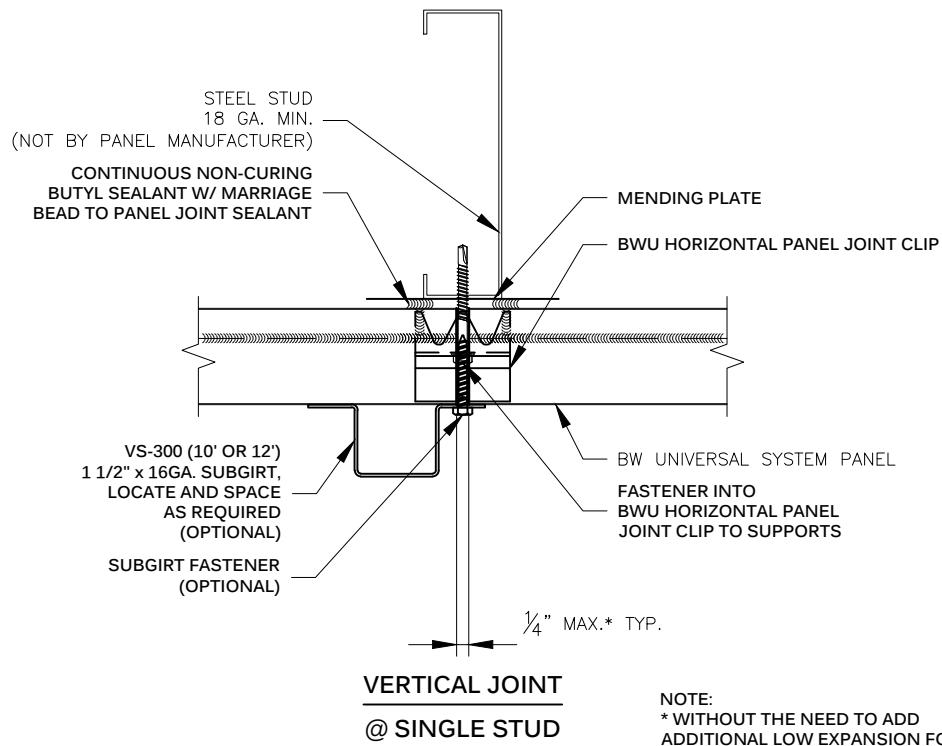

METL SPAN®
INSULATED METAL PANELS

NOTE:
THESE DETAILS ARE FOR INSTALLATION AND SEALING OF BW UNIVERSAL SYSTEM PANELS ONLY. FOR INSTALLATION AND SEALING REQUIRED FOR CLADDING, SEE STANDARD DETAILS FOR SPECIFIC CLADDING.

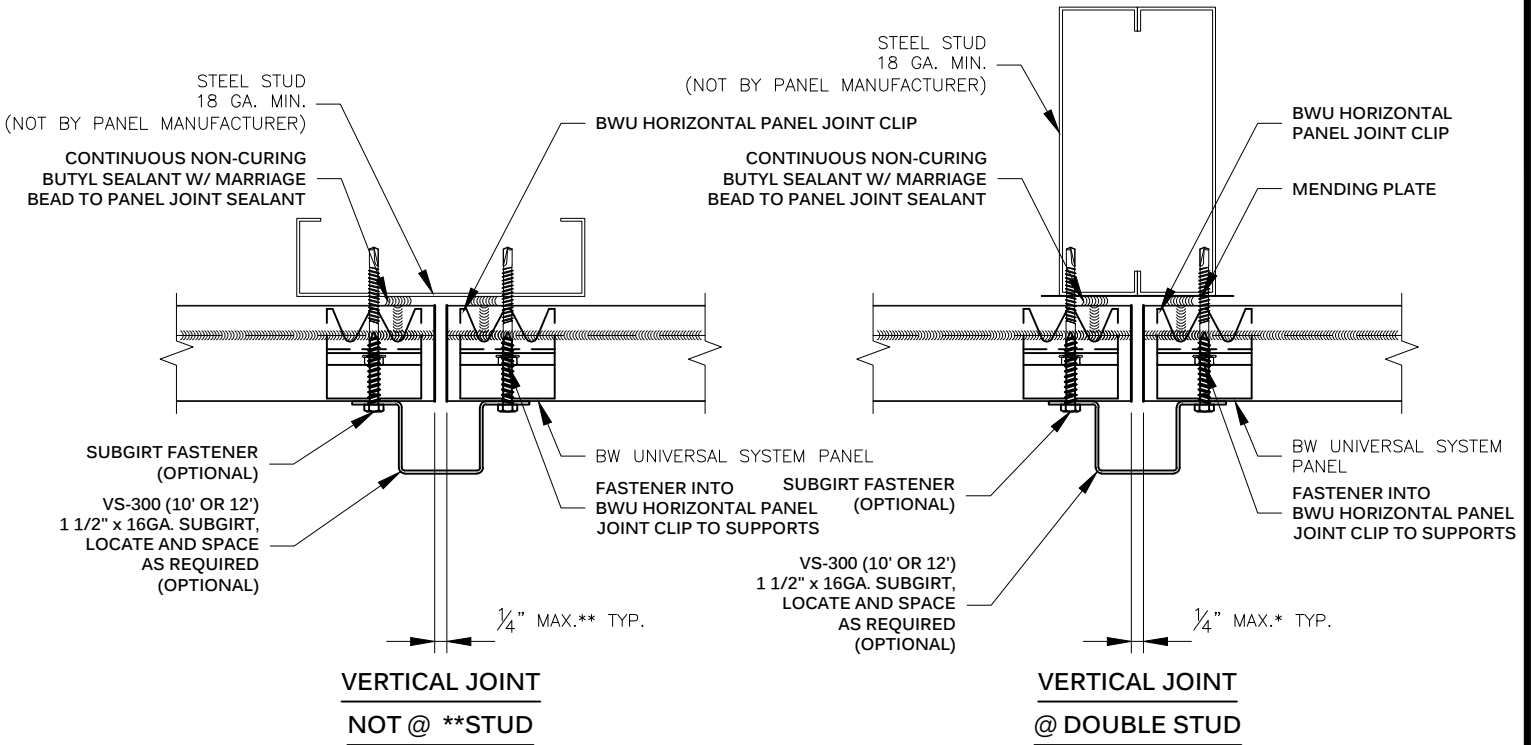

NOTE:
* WITHOUT THE NEED TO ADD ADDITIONAL LOW EXPANSION FOAM
** LIMITED TO STANDARD 16" TO 24" STUD SPACING

**HORIZONTAL PANEL JOINT CLIP
VERTICAL JOINT
BW UNIVERSAL SYSTEM™**

DRAWING NO:
BWU-HPJC-VJ-01

DATE:
Feb '20

REV:
00