

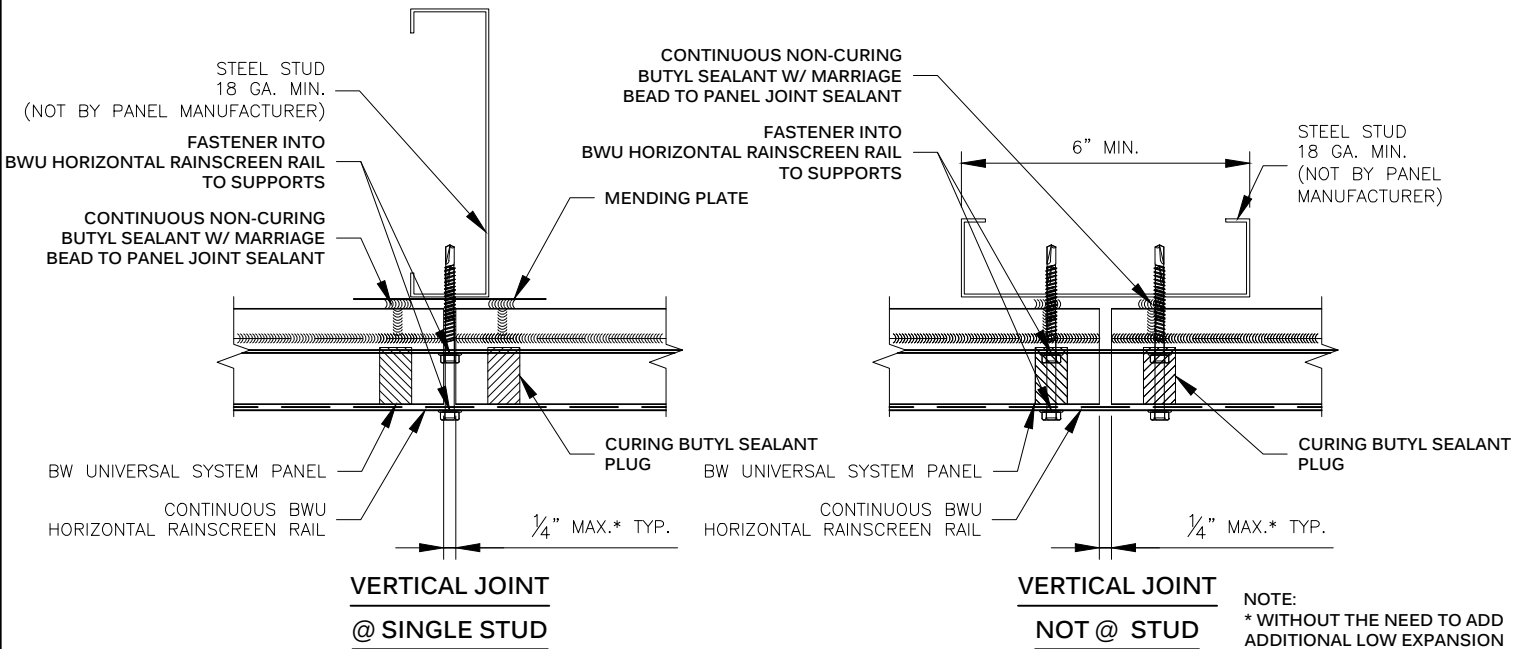

**METL SPAN®**  
INSULATED METAL PANELS



**VERTICAL JOINT  
@ SINGLE STUD**

**VERTICAL JOINT  
NOT @ STUD**

NOTE:  
\* WITHOUT THE NEED TO ADD  
ADDITIONAL LOW EXPANSION  
FOAM  
\*\* LIMITED TO STANDARD  
16" TO 24" STUD SPACING

**HORIZONTAL SECTION**

**APPROVED METHODS OF PANEL SUPPORT**

APPLY (2) 3/8" Ø BEADS OF  
NON-CURING BUTYL SEALANT  
TO MENDING PLATE AT PANEL ENDS,  
JOINTS, PERIMETERS AND CUT EDGES.

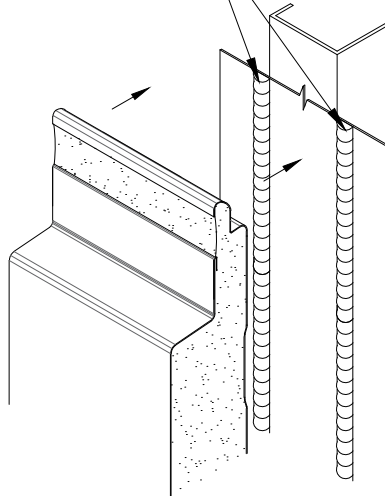

APPLY 3/8" Ø BEAD OF NON-CURING BUTYL SEALANT  
OVER PANEL LINER MALE LEG AS SHOWN. THIS  
"MARRIAGE BEAD" WILL CONNECT TO THE FACTORY  
APPLIED NON-CURING BUTYL SEALANT IN THE SIDE  
JOINT OF THE PANEL ABOVE TO THE FIELD APPLIED  
BUTYL OF THE MENDING PLATE AT THE PANEL ENDS.

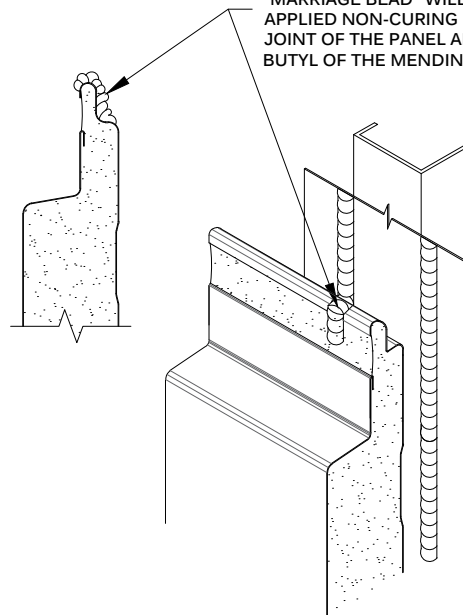

**THE VERTICAL JOINT SEALANT  
AND MARRIAGE BEAD**

**HORIZONTAL RAINSCREEN RAIL - VERTICAL JOINT  
BW UNIVERSAL SYSTEM™**

DRAWING NO: <b>BWU-HRAIL-VJ-01</b>	
DATE: <b>Feb '20</b>	REV: <b>00</b>