

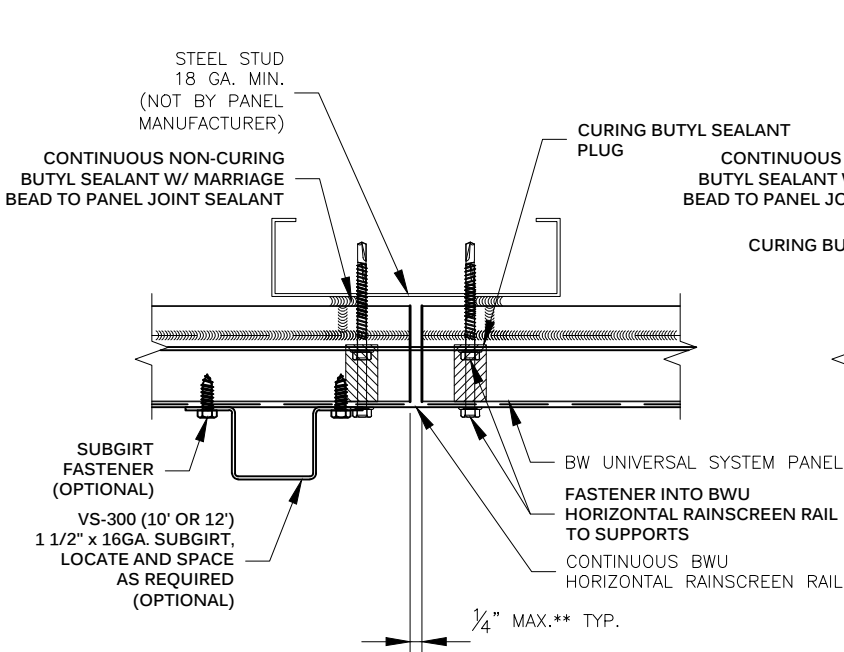

METL SPAN®
INSULATED METAL PANELS

NOTE:
THESE DETAILS ARE FOR INSTALLATION AND SEALING OF BW UNIVERSAL SYSTEM PANELS ONLY. FOR INSTALLATION AND SEALING REQUIRED FOR CLADDING, SEE STANDARD DETAILS FOR SPECIFIC CLADDING.



VERTICAL JOINT
NOT @ **STUD

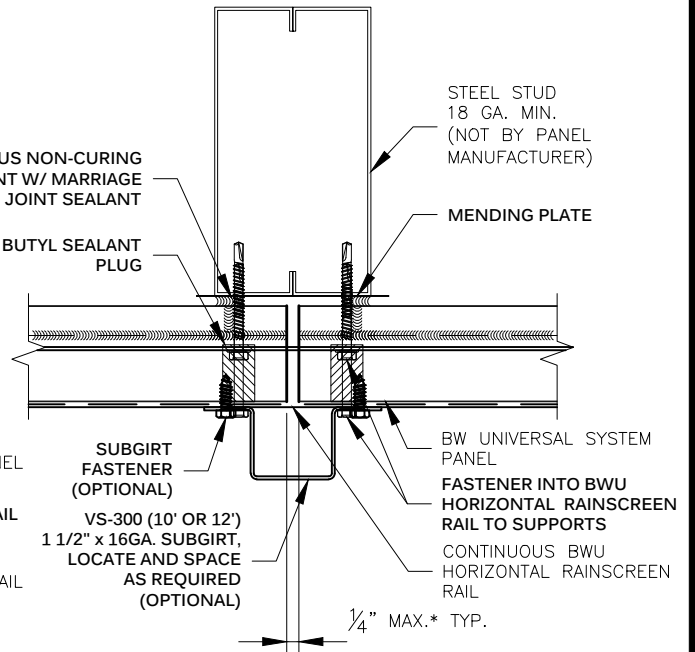

VERTICAL JOINT
@ DOUBLE STUD

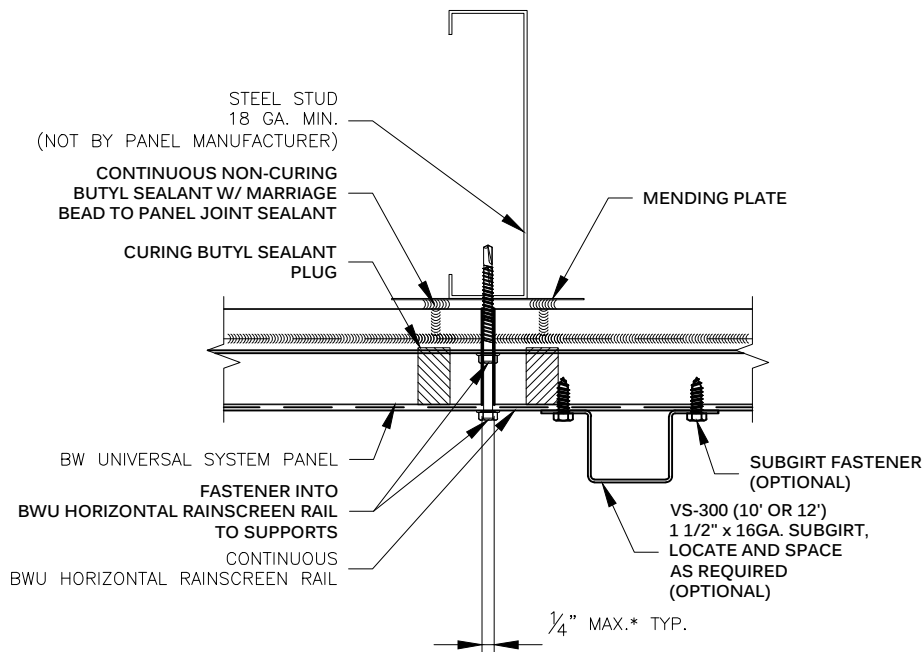

VERTICAL JOINT
@ SINGLE STUD

NOTE:
* WITHOUT THE NEED TO ADD ADDITIONAL LOW EXPANSION FOAM
** LIMITED TO STANDARD 16" TO 24" STUD SPACING

**HORIZONTAL RAINSCREEN RAIL
VERTICAL JOINT w/1 1/2" SUBGIRT
BW UNIVERSAL SYSTEM™**

DRAWING NO:
BWU-HRAIL-VJ-01A
DATE: Feb '20 REV: 00