

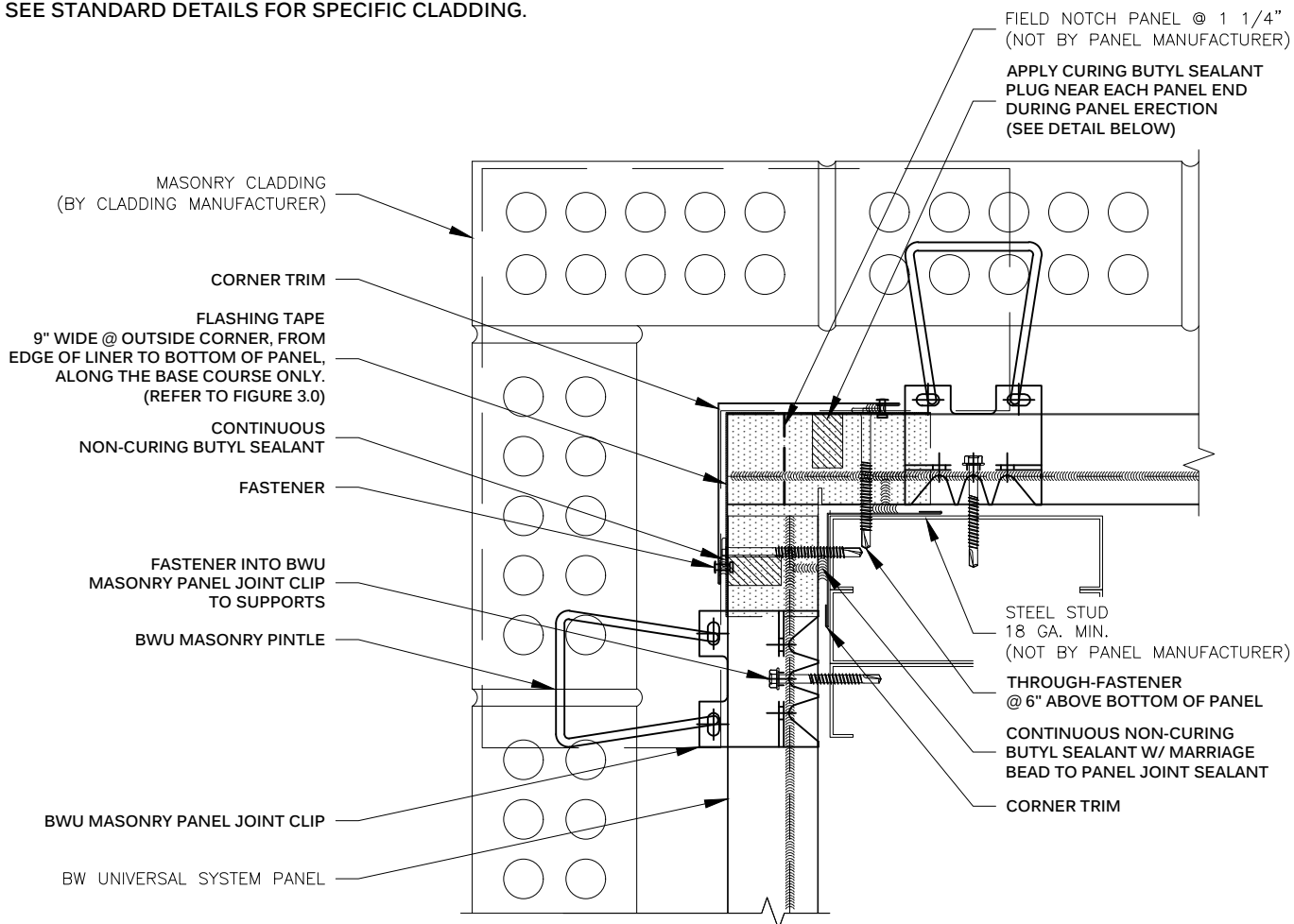

**METL SPAN**<sup>®</sup>

INSULATED METAL PANELS

**NOTE:**  
THESE DETAILS ARE FOR INSTALLATION AND SEALING OF BW UNIVERSAL SYSTEM PANELS ONLY. FOR INSTALLATION AND SEALING REQUIRED FOR CLADDING, SEE STANDARD DETAILS FOR SPECIFIC CLADDING.



FLASHING TAPE, 9" WIDE FROM EDGE OF THE LINER TO THE BOTTOM OF THE PANEL ALONG THE BASE COURSE ONLY

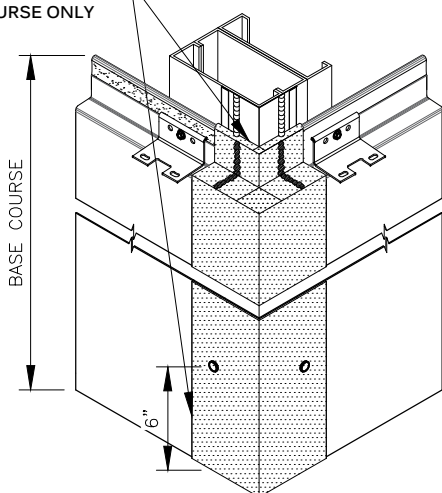

**FIGURE 3.0**

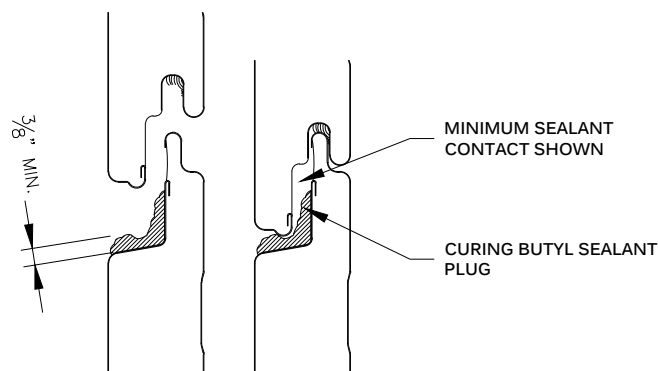

**SEALANT PLUG DETAIL**

APPLY SEALANT AS PANELS ARE ERECTED

**MASONRY PANEL JOINT CLIP  
OUTSIDE CORNER  
BW UNIVERSAL SYSTEM™**

DRAWING NO:

**BWU-MAS-CE-01**

DATE:

Feb '20

REV:

00