



METL SPAN
INSULATED METAL PANELS

NOTE:
THESE DETAILS ARE FOR INSTALLATION AND SEALING OF BW UNIVERSAL SYSTEM PANELS ONLY. FOR INSTALLATION AND SEALING REQUIRED FOR CLADDING, SEE STANDARD DETAILS FOR SPECIFIC CLADDING.

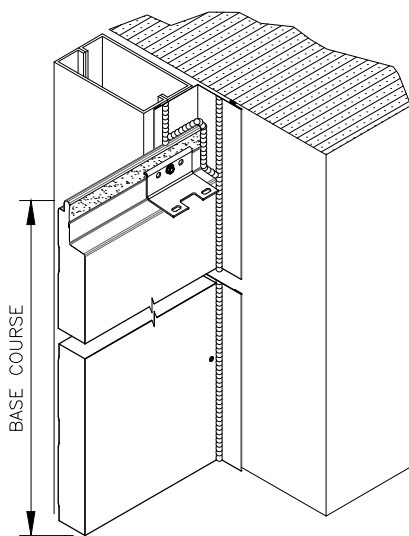
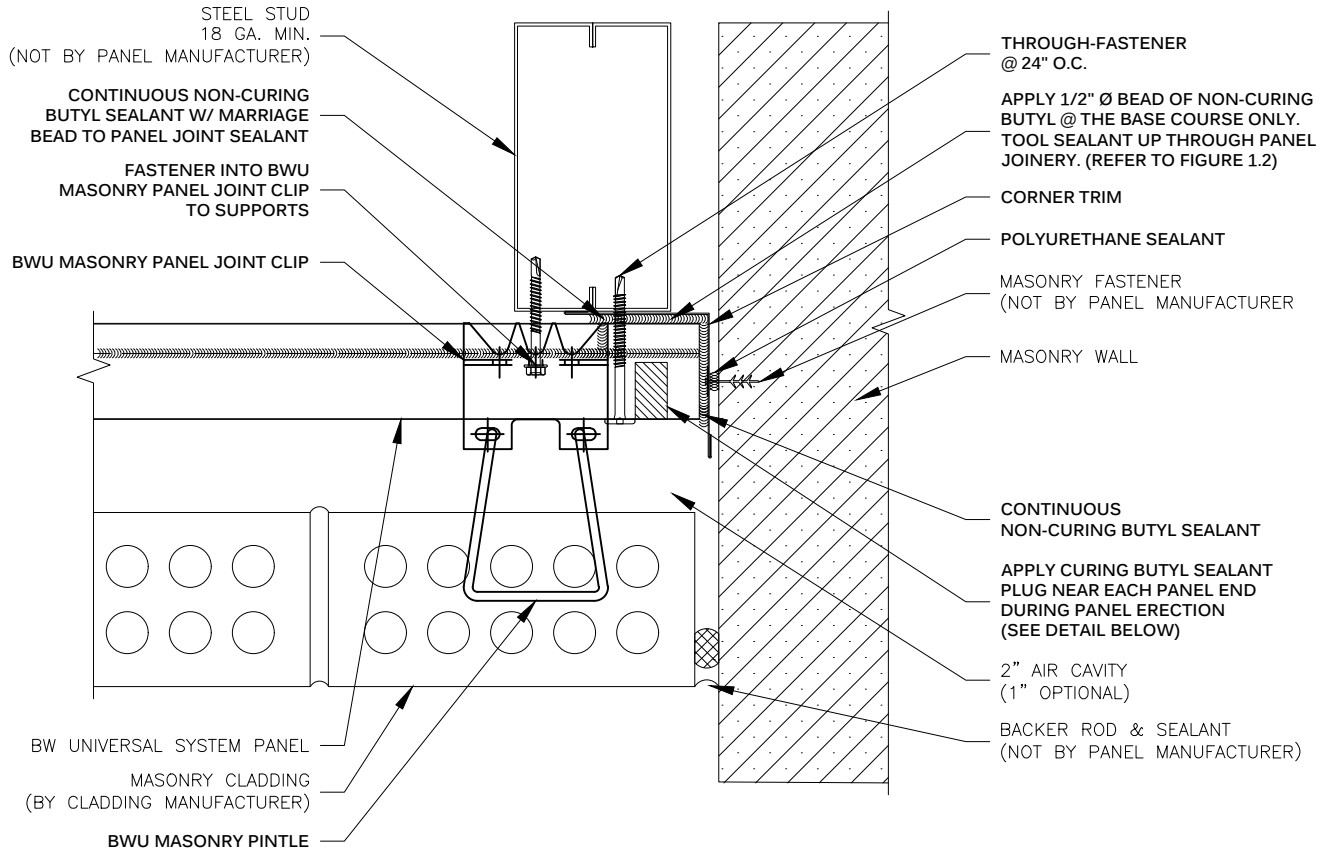
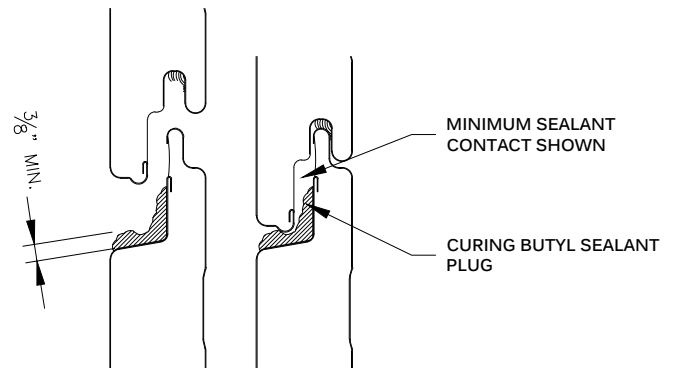

FIGURE 3.2



SEALANT PLUG DETAIL

APPLY SEALANT AS PANELS ARE ERECTED

**MASONRY PANEL JOINT CLIP
ENDWALL
BW UNIVERSAL SYSTEM™**

DRAWING NO:
BWU-MAS-EW-01

DATE: **Feb '20** REV: **00**