

Metl-Span CF-42 Tuff Wall/Tuff-Cast Wall Panels

24 Ga. Exterior / 26 Ga. Interior Facings

Allowable Connection Load^{1,7,8,9,10} (psf) Two or More Equal Spans

Panel Type ²	Design Criteria ^{3,4,5,6}	Support Span							
		5 ft	6 ft	7 ft	8 ft	9 ft	10 ft	11 ft	12 ft
2" Thick	Connection FP1	31.7	25.9	21.8	18.8	16.6	14.8	13.4	12.2
	Connection FP2	46.3	37.8	31.9	27.6	24.2	21.6	19.5	17.8
	Connection FP3	58.5	47.7	40.3	34.8	30.6	26.4	22.3	19.0
2½" Thick	Connection FP1	33.5	27.3	23.0	19.8	17.4	15.5	14.0	12.8
	Connection FP2	47.7	38.9	32.8	28.3	24.9	22.2	20.0	18.2
	Connection FP3	60.3	49.2	41.5	35.8	31.4	28.0	25.3	23.0
3" Thick	Connection FP1	35.2	28.8	24.2	20.9	18.3	16.3	14.7	13.4
	Connection FP2	48.9	40.0	33.7	29.0	25.5	22.7	20.5	18.6
	Connection FP3	62.0	50.7	42.7	36.8	32.3	28.8	25.9	23.6
	Connection FP4	71.3	58.3	49.1	42.3	37.1	33.1	29.8	27.1
4" Thick	Connection FP1	43.3	35.5	29.9	25.8	22.6	20.1	18.1	16.4
	Connection FP2	63.5	52.0	43.8	37.8	33.1	29.5	26.5	24.1
	Connection FP3	74.9	61.3	51.7	44.6	39.1	34.8	31.3	28.4
	Connection FP4	80.2	65.7	55.4	47.7	41.9	37.2	33.5	30.5
	Connection FP5	83.9	68.7	57.9	49.9	43.8	39.0	35.1	31.9
	Connection FP9	90.2	73.8	62.3	53.7	47.1	41.9	37.7	34.3
	Connection FP10	94.3	77.3	65.1	56.1	49.3	43.8	39.4	35.8
5" Thick ²	Connection FP1	43.9	36.0	30.4	26.2	23.0	20.4	18.4	16.7
	Connection FP2	64.3	52.7	44.5	38.4	33.7	30.0	27.0	24.5
	Connection FP3	75.8	62.2	52.5	45.3	39.7	35.3	31.8	28.9
	Connection FP4	81.2	66.6	56.3	48.5	42.6	37.9	34.1	30.9
	Connection FP5	85.0	69.7	58.9	50.8	44.5	39.6	35.6	32.4
	Connection FP9	91.3	74.9	63.3	54.6	47.9	42.6	38.3	34.8
	Connection FP10	95.5	78.4	66.2	57.1	50.1	44.5	40.1	36.4
6" Thick ²	Connection FP1	44.4	36.5	30.9	26.7	23.4	20.8	18.7	17.0
	Connection FP2	65.0	53.5	45.3	39.1	34.3	30.5	27.5	24.9
	Connection FP3	76.7	63.1	53.4	46.1	40.5	36.0	32.4	29.4
	Connection FP4	82.2	67.6	57.2	49.4	43.4	38.6	34.7	31.5
	Connection FP5	86.0	70.7	59.8	51.7	45.4	40.4	36.3	32.9
	Connection FP9	92.4	76.0	64.3	55.5	48.8	43.4	39.0	35.4
	Connection FP10	96.6	79.5	67.3	58.1	51.0	45.4	40.8	37.0

Notes:

1. The Load Span Table above is based on Allowable Stress Design (ASD). For loads calculated based on ASCE 7-10 (LRFD), please refer to section 2.4.1 of ASCE 7-10 for the applicable load combinations using Allowable Stress Design.
2. Based on CF-42 panel with 24 ga. Tuff Wall/Tuff-Cast exterior and 26 ga. Light Mesa interior face (min F_y = 33 ksi). For 5" and 6" thick panels, the exterior face is min. 26 ga. Mesa.
3. Fastener pattern FP1 is based on CF panel clips fastened to min. 14 ga. steel. Fastener options will be (2) ¼"-14 SDS Type 3, (2) ¼"-14 Self-Tapping, (2) ¼"-14 Type 5 SDS, (2) ¼"-20 Type 5 SDS, or (2) ¼"-28 Type 5 SDS. Fastener selection will be based on fastener pullout capacity from support steel members.
4. The fastener pattern, FP2, FP3, FP4, and FP5 includes CF panel clip attachment plus 1, 2, 3, and 4 blind rivets, respectively, at supports per panel width. Blind rivet spacing is 10.5" o.c. from female edge of panel seam.
5. The through fasteners (FP9) are as follows: Panels fastened to min. 14 ga. steel supports with (4) ¼"-14 SDS Type 3, (4) ¼"-14 Self-Tapping, (4) ¼"-14 Type 5 SDS, (4) ¼"-20 Type 5 SDS, or (4) ¼"-28 Type 5 SDS with nominal 5/8" diameter neoprene bonded washers spaced at 8.4" o.c. Fastener shall be of sufficient length to penetrate through the support a minimum of ¾". Fastener selection will be based on fastener pullout capacity from support steel members.
6. The through fasteners (FP10) are as follows: Panels fastened to min. 14 ga. steel supports with (5) ¼"-14 SDS Type 3, (5) ¼"-14 Self-Tapping, (5) ¼"-14 Type 5 SDS, (5) ¼"-20 Type 5 SDS, or (5) ¼"-28 Type 5 SDS with nominal 5/8" diameter neoprene bonded washers spaced at 8.4" o.c. Fastener shall be of sufficient length to penetrate through the support a minimum of ¾". Fastener selection will be based on fastener pullout capacity from support steel members.
7. Allowable positive or suction load is the lowest value of panel bending strength, shear strength, deflection limit and connection strength for each fastener pattern.
8. Allowable loads based on panel stress and deflection design criteria are derived from ASTM E72 structural testing and calculated with factor of safety of 2.5 for bending stress, 3.0 for shear stresses and deflection limitation of L/180.
9. The panel connection strength was determined from ASTM E1592 testing and the allowable loads are calculated with factor of safety of 2.
10. The structural capacity of the purlins are not considered and must be examined independently.

Metl-Span CF-36 Tuff Wall/Tuff-Cast Wall Panels
24 Ga. Exterior / 26 Ga. Interior Facings
Allowable Connection Load^{1,6,7,8} (psf) for Two or More Equal Spans

Panel Type ²	Fastener ^{3,4,5}	Thickness	Support Span								
			4 ft	5 ft	6 ft	7 ft	8 ft	9 ft	10 ft	11 ft	12 ft
36" wide	FP1	2"	54.6	42.6	34.8	29.3	25.3	22.3	19.9	18.0	16.4
		2.5"	56.4	44.1	36.0	30.3	26.2	23.0	20.5	18.5	16.8
		3"	58.2	45.5	37.2	31.3	27.0	23.7	21.1	19.0	17.3
		4"	61.3	48.2	39.4	33.2	28.7	25.1	22.4	20.1	18.3
	FP2	2"	65.7	51.2	41.8	35.3	30.5	26.8	23.9	21.6	19.0
		2.5"	71.0	55.5	45.3	38.2	32.9	29.0	25.8	23.3	21.2
		3"	76.3	59.7	48.8	41.1	35.4	31.1	27.7	25.0	22.7
		4"	86.6	68.1	55.7	47.0	40.5	35.5	31.6	28.5	25.9
	FP3	2"	87.9	68.6	56.0	46.3	38.1	31.6	26.4	22.3	19.0
		2.5"	89.6	70.0	57.2	48.2	41.6	36.5	32.6	29.4	25.5
		3"	91.1	71.3	58.2	49.1	42.3	37.1	33.1	29.8	27.1
		4"	93.4	73.4	60.1	50.7	43.7	38.3	34.1	30.7	27.9

Notes:

1. The Load Span Table above is based on Allowable Stress Design (ASD). For loads calculated based on ASCE 7-10 (LRFD), please refer to section 2.4.1 of ASCE 7-10 for the applicable load combinations using Allowable Stress Design.
2. Based on CF-panel with 24 ga. Tuff Wall/Tuff-Cast exterior and 26 ga. Light Mesa interior face (min $F_y = 33$ ksi).
3. Fastener pattern FP1 is based on CF panel clips fastened to min. 14 ga. steel. Fastener options will be (2) ¼"-14 SDS Type 3, (2) ¼"-14 Self-Tapping, (2) ¼"-14 Type 5 SDS, (2) ¼"-20 Type 5 SDS, or (2) ¼"-28 Type 5 SDS. Fastener selection will be based on fastener pullout capacity from support steel members.
4. Pattern FP2 is based on FP1 along with (1) blind rivet at 12" o.c. from female panel sidelap.
5. Pattern FP3 is based on FP1 along with (2) blind rivets at 12" o.c. from female panel sidelap.
6. Allowable loads based on panel stress, connection strength and deflection design criteria are derived from ASTM E72 and E1592 structural testing.
7. The allowable inward or outward loads is the smallest load calculated with a factor of safety of 2.5 for bending stress, 3.0 for shear stresses, 2.0 for connection and deflection limitation of L/180.
8. The structural capacity of the supports are not considered and must be examined independently.

Metl-Span Tuff Wall/Tuff-Cast Wall Panels⁷

24 Ga. Exterior / 26 Ga. Interior Facings

Allowable Positive Load^{1,4,5,6} (psf) for Two or More Equal Spans

Panel Type ²	Design Criteria ³	Support Span							
		5 ft	6 ft	7 ft	8 ft	9 ft	10 ft	11 ft	12 ft
2" Thick	Bending & Shear	71.3	58.6	49.8	43.2	38.0	31.6	25.1	20.5
	Deflection (L/180)	72.5	57.2	46.3	38.1	31.6	26.4	22.3	19.0
2½" Thick	Bending & Shear	81.1	66.6	56.5	49.1	43.2	38.6	31.6	25.5
	Deflection (L/180)	89.2	71.0	58.0	48.4	40.8	34.6	29.6	25.5
3" Thick	Bending & Shear	90.1	73.9	62.6	54.3	47.9	42.9	37.9	30.4
	Deflection (L/180)	103.7	83.1	68.4	57.4	48.9	42.1	36.3	31.6
4" Thick	Bending & Shear	95.3	78.1	66.1	57.2	50.4	45.1	40.7	37.2
	Deflection (L/180)	125.9	101.8	84.6	71.7	61.6	53.6	47.1	41.7
5" Thick	Bending & Shear	107.1	87.8	74.2	64.2	56.5	50.4	45.6	41.5
	Deflection (L/180)	150.6	122.5	102.3	87.2	75.4	65.9	58.3	51.9
6" Thick	Bending & Shear	119.4	98.0	82.8	71.6	63.0	56.2	50.7	46.2
	Deflection (L/180)	160.3	131.1	110.1	94.2	81.9	72.0	63.9	57.2

Notes:

1. The Load Span Table above is based on Allowable Stress Design (ASD). For loads calculated based on ASCE 7-10 (LRFD), please refer to section 2.4.1 of ASCE 7-10 for the applicable load combinations using Allowable Stress Design.
2. Based on CF-panel with 24 ga. Tuff Wall/Tuff-Cast exterior and 26 ga. Light Mesa interior face (min $F_y = 33$ ksi). For 5" and 6" thick panels, the exterior face is 26 ga. Mesa.
3. Refer to the allowable connection load chart, for suction loads.
4. Allowable positive or suction load is the lowest value of panel bending strength, shear strength, deflection limit and connection strength for each fastener pattern.
5. Allowable loads based on panel stress and deflection design criteria are derived from ASTM E72 structural testing and calculated with factor of safety of 2.5 for bending stress, 3.0 for shear stresses and deflection limitation of L/180.
6. The structural capacity of the purlins are not considered and must be examined independently.
7. Consult Metl-Span for recommendations on panel profile and gauge suitable for thermal stresses.



SUPPORT
(NOT BY METL-SPAN)

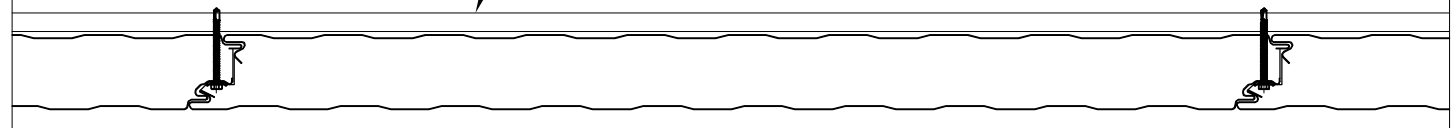

(FP1) SIDE JOINT CLIP ONLY

FROM FEMALE
EDGE (CRITICAL)

SUPPORT
(NOT BY METL-SPAN)

10.5"

10.5"

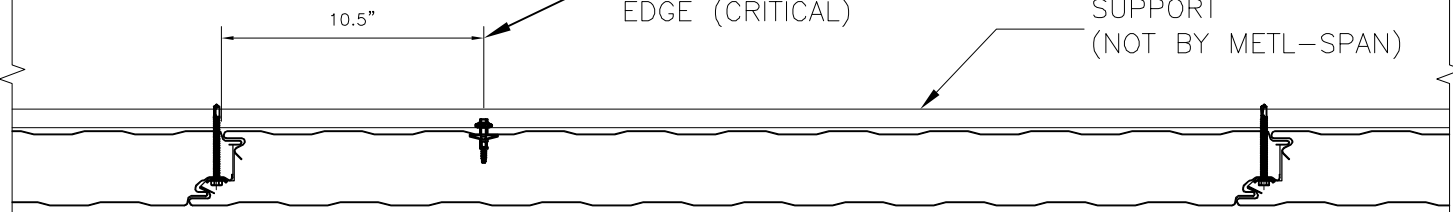

(FP2) SIDE JOINT AND (1) BLIND RIVET

SUPPORT
(NOT BY METL-SPAN)

10.5"

10.5"

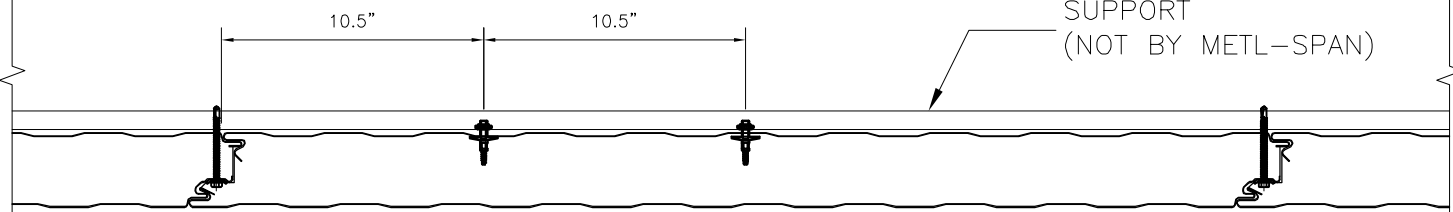

(FP3) SIDE JOINT AND (2) BLIND RIVETS

SUPPORT
(NOT BY METL-SPAN)

10.5"

10.5"

10.5"

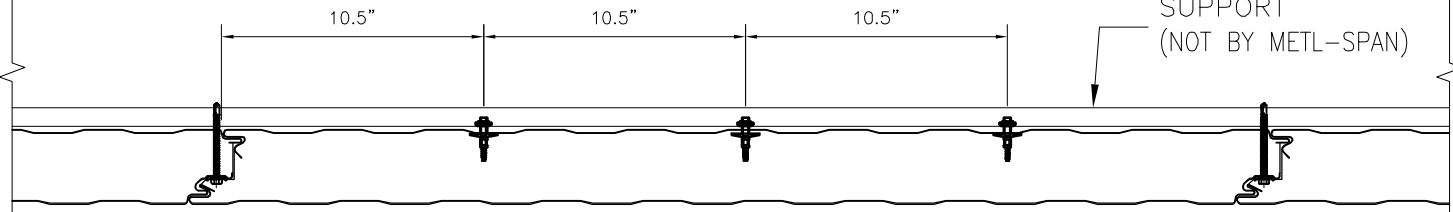

(FP4) SIDE JOINT AND (3) BLIND RIVETS

CF42 FASTENING PATTERNS

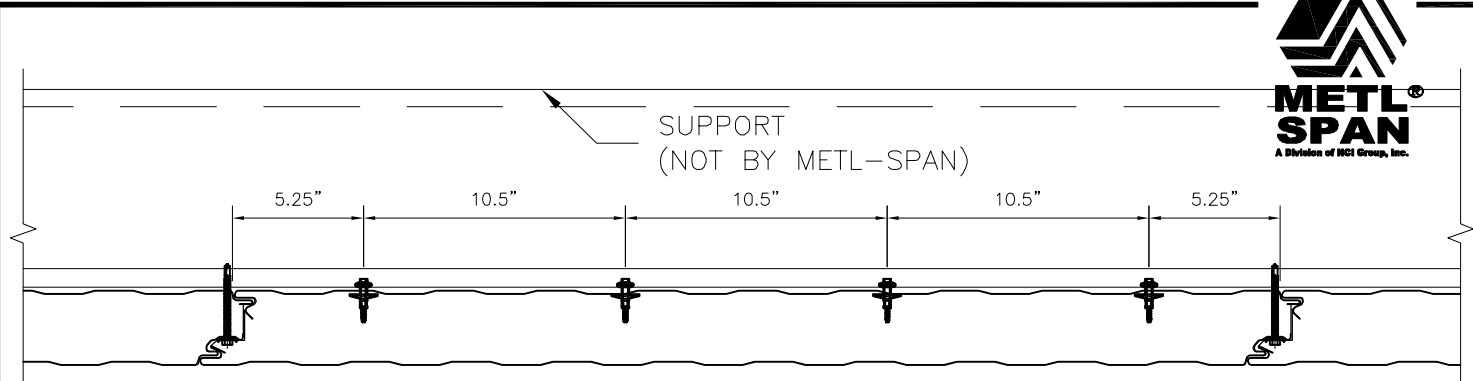

(FP5) SIDE JOINT AND (4) BLIND RIVETS

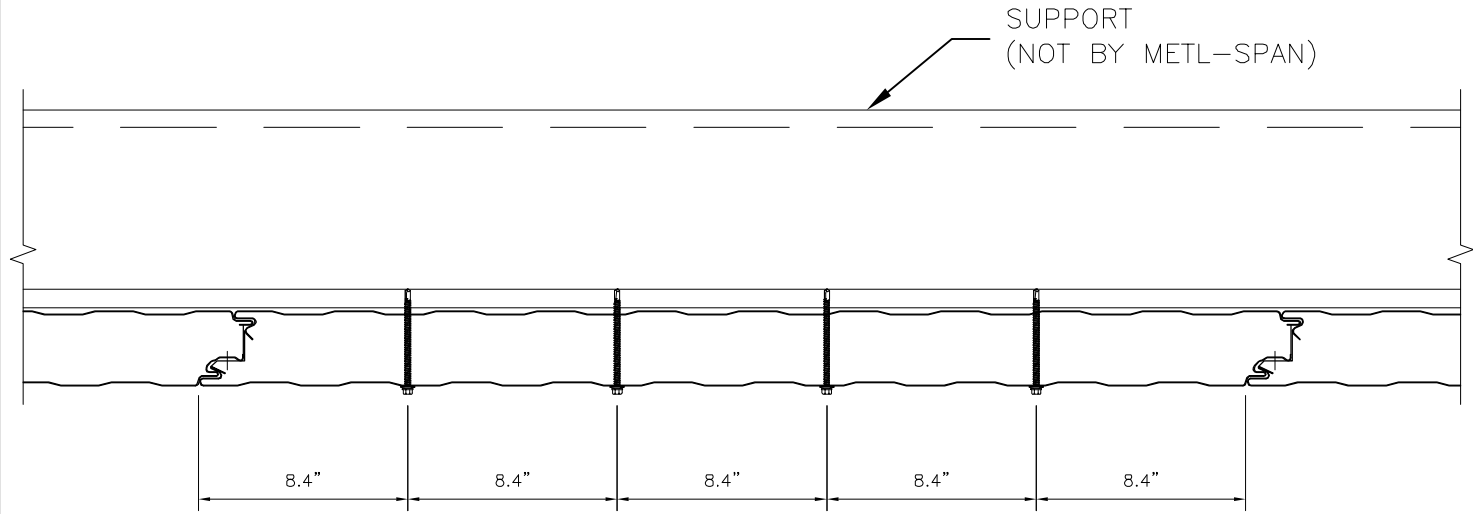

(FP9) (4) SELF-DRILLING OR SELF-TAPPING FASTENERS W/ NEOPRENE BONDED WASHER

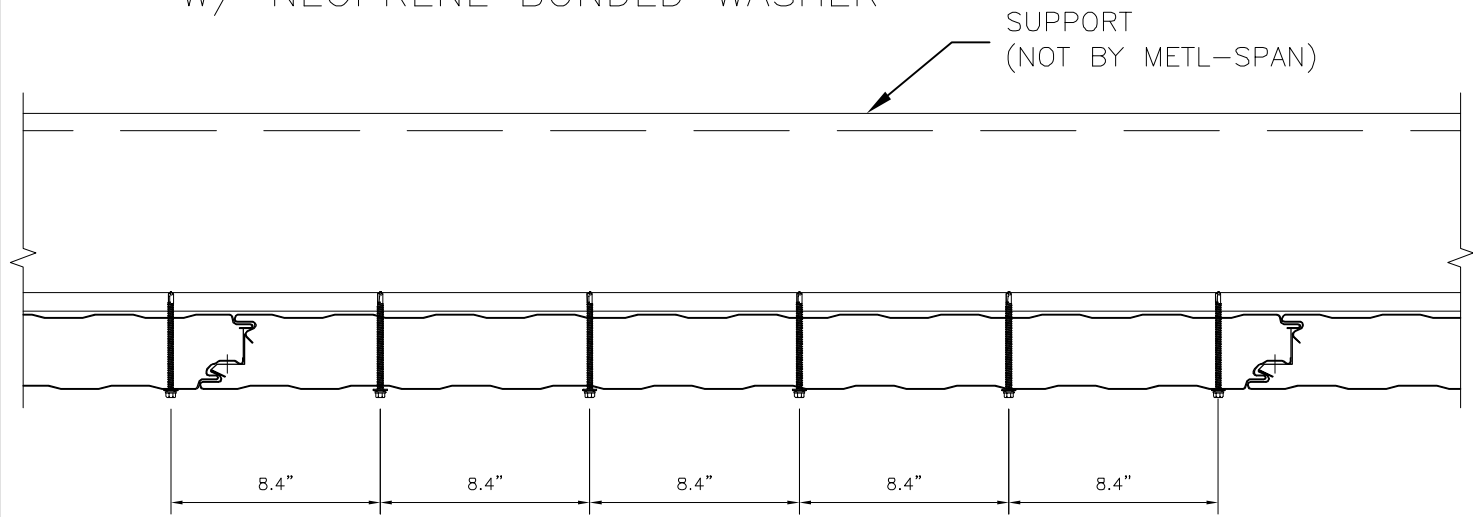

(FP10) (5) SELF-DRILLING OR SELF-TAPPING FASTENERS W/ NEOPRENE BONDED WASHER

CF42 FASTENING PATTERNS

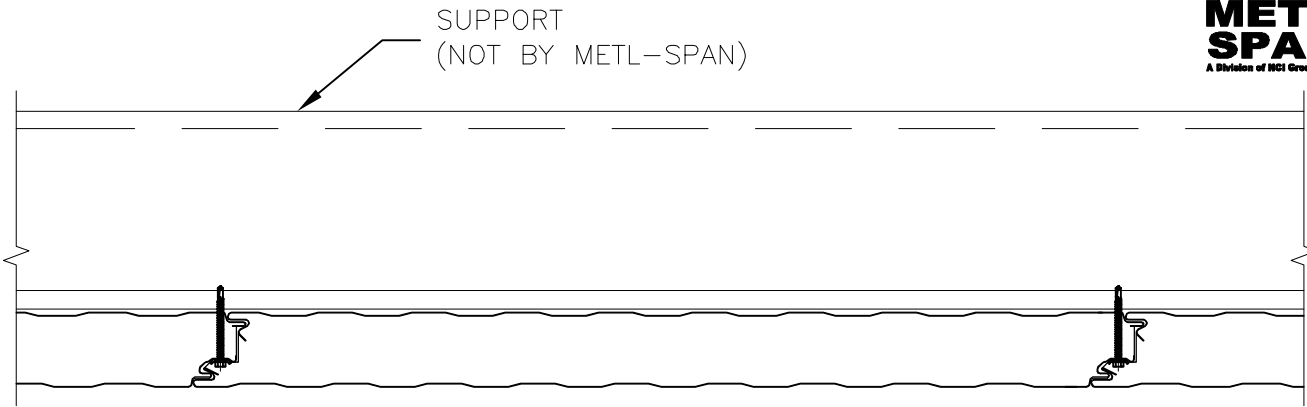

(FP1) SIDE JOINT CLIP ONLY

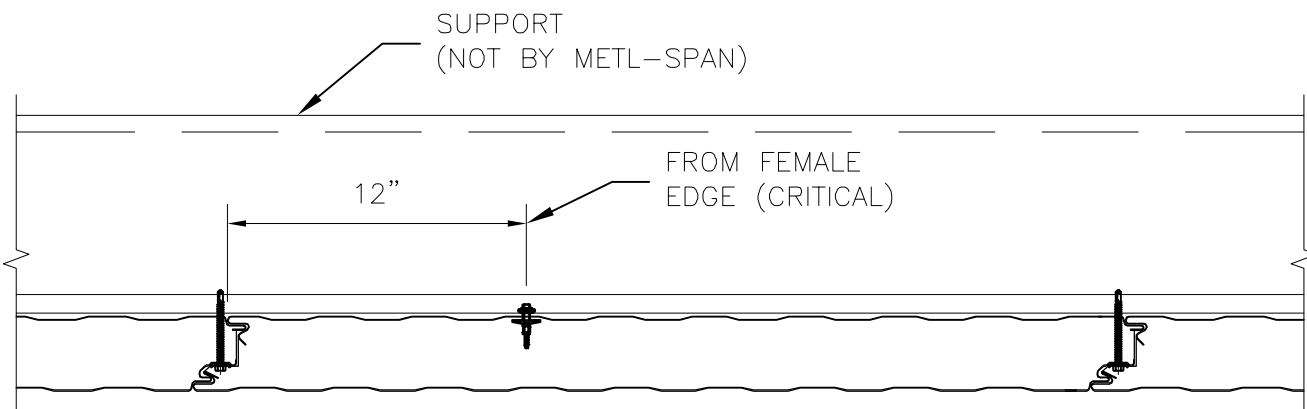

(FP2) SIDE JOINT AND (1) BLIND RIVET

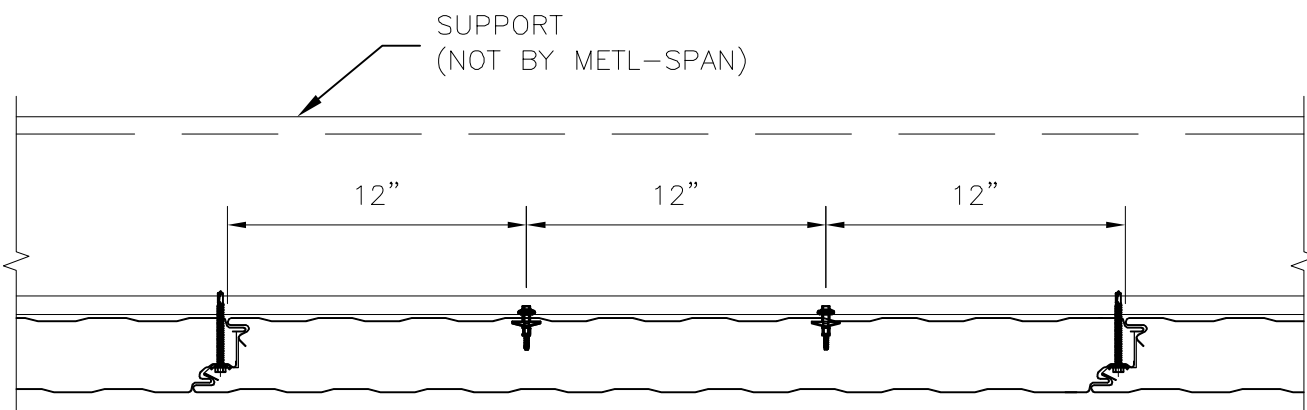

(FP3) SIDE JOINT AND (2) BLIND RIVETS

CF36 FASTENING PATTERNS