

## Construction No. 500 TGKX.500 Roof Deck Constructions

[Page Bottom](#)

### Design/System/Construction/Assembly Usage Disclaimer

- Authorities Having Jurisdiction should be consulted in all cases as to the particular requirements covering the installation and use of UL Certified products, equipment, system, devices, and materials.
- Authorities Having Jurisdiction should be consulted before construction.
- Fire resistance assemblies and products are developed by the design submitter and have been investigated by UL for compliance with applicable requirements. The published information cannot always address every construction nuance encountered in the field.
- When field issues arise, it is recommended the first contact for assistance be the technical service staff provided by the product manufacturer noted for the design. Users of fire resistance assemblies are advised to consult the general Guide Information for each product category and each group of assemblies. The Guide Information includes specifics concerning alternate materials and alternate methods of construction.
- Only products which bear UL's Mark are considered Certified.

### Roof Deck Constructions

[See General Information for Roof Deck Constructions](#)

## Construction No. 500

March 11, 2013

**Uplift – Class 90**

**Fire Not Investigated**

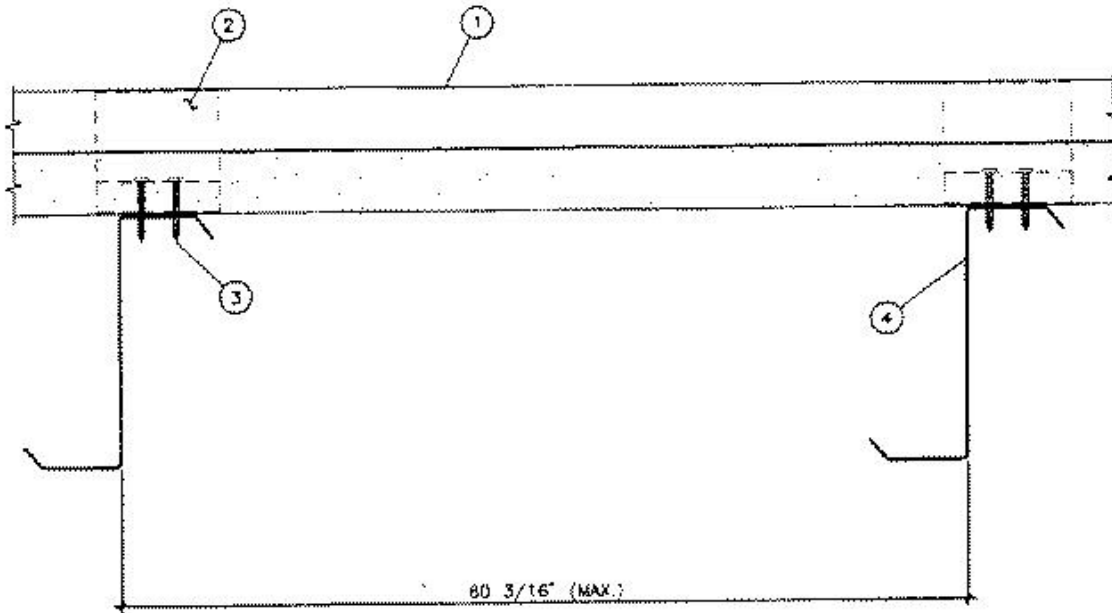

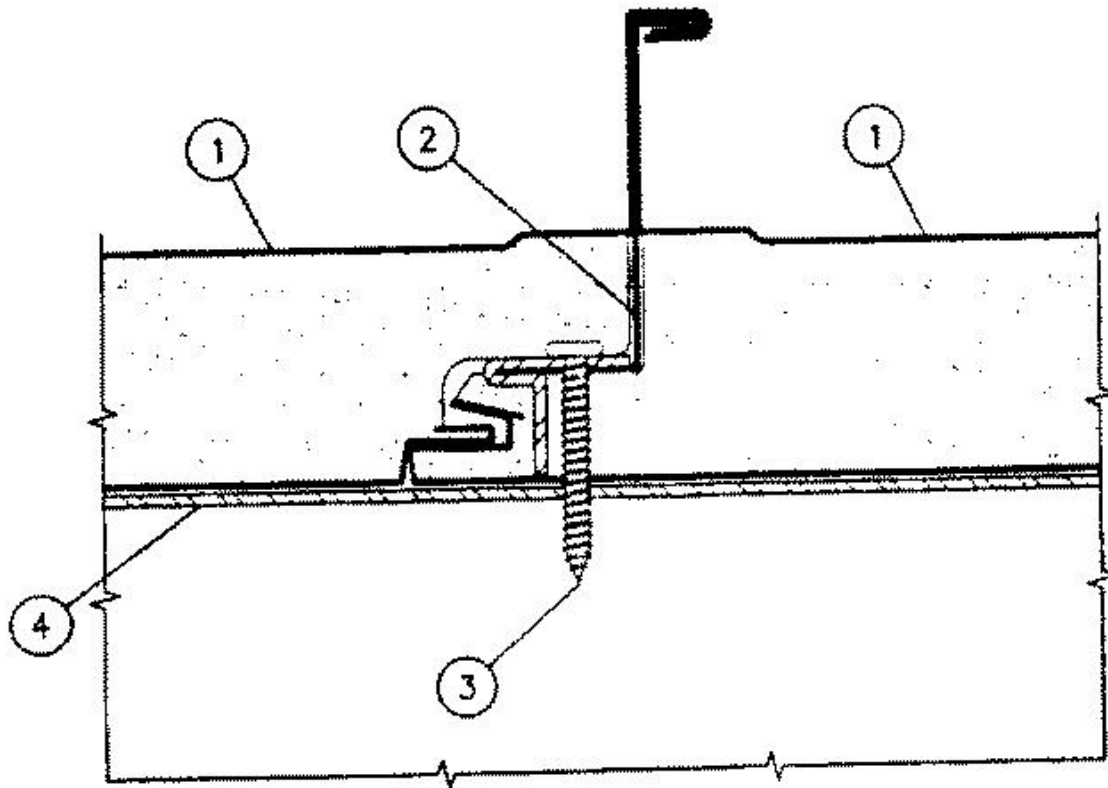

1. **Building Units\*** — Sandwich panels, max width 42 in., 2 in. high standing seams (ribs); min 2 in., max 6 in. thick foamed plastic core, No. 24 MSG min thick coated exterior steel face, No. 26 MSG min thick coated interior steel face. Building Units continuous over two or more spans. End laps to be continuous and to occur over a purlin and end lap support angle. End lap foamed by a 3 in. cutback of the foamed core from upslope unit and butting the foam cores, lapping the exterior upper faces 3 in., and securing the lap with fasteners and back-up plates at 8 in. max spacing. Side laps to be seamed with manual or motorized seaming tool. Sealant may be used at unit side joints and unit end laps.

**METL-SPAN, A DIVISION OF NCI GROUP, INC.** ([View Classification](#)) — "Metl-Span CFR Insulated Metal Panel"

**METL-SPAN, A DIVISION OF NCI GROUP, INC.** ([View Classification](#)) — "CFR Roof Panel"

**METL-SPAN, A DIVISION OF NCI GROUP, INC.** ([View Classification](#)) — Panel clip fasteners identified as "A", "B", "C", "D", "E", "F"

**NCI BUILDING SYSTEMS L P** ([View Classification](#)) — "IBL Roof Panel (2)", "IBL Roof Panel"

2. **Roof Deck Fasteners\*(Panel Clips)** — Two piece assembly, base fabricated from No. 12 MSG min thick coated steel, tab fabricated from No. 20 MSG min thickness coated steel, 4 in. long. Height varies with foam core thickness. Four 9/32 in. guide holes in base. Clips installed on unit side laps at purlins and end lap support angle.

**METL-SPAN, A DIVISION OF NCI GROUP, INC.** ([View Classification](#)) — "CFR PANEL CLIP"

**NCI BUILDING SYSTEMS L P** ([View Classification](#)) — Panel clip fasteners identified as "HW-2324A", "HW-2324B", "HW-2324C", "HW-2324D", "HW-2324E", "HW-2324F"

3. **Fasteners (Screws)** — For panel clip (Item 2) to No. 16 MSG thick purlins, No. 1/4 - 14 by min 1-1/2 in. long, self-tapping, pan head, plated steel screws. Two screws used per clip.

3a. **Alternate Fasteners (Screws) — (Not Shown)** — For panel clip (item 2) to No. 16 MSG thick purlins, No. 1/4 in. - 14 by min 1-3/4 in. long, self-drilling (TEK® 2 point), self-tapping, pan head, plated steel screws. Two screws used per clip.

3b. **Alternate Fasteners (Screws) — (Not Shown)** — For panel clip (item 2) to No. 14 MSG thick purlins, No. 1/4 - 14 in., 1-3/4 in. long, self-drilling, (TEK® 3 point), self-tapping, pan head, plated steel screws. Two screws used per clip.

3c. **Alternate Fasteners (Screws) — (Not Shown)** — For panel clip (item 2) to No. 12 MSG thick purlins, No. 12 - 24 by min 1-3/4 in. long, self-tapping, pan head, plated steel screws. Two screws used per clip.

3d. **Alternate Fasteners (Screws) — (Not Shown)** — For panel clip (Item 2) to wood purlins, No. 9-15 by min 2 in. long, self-tapping, pan head, plated steel, wood screws. Min 1-1/2 in. penetration into wood. Two screws per clip.

3e. **Fasteners (Screws) — (Not Shown)** — For building unit end-lap connections, to be No. 14 - 14 by min 3/4 in. long self-drilling, self-tapping, plated steel or stainless steel, hex-head screws with 1-1/8 in. diam steel backed sealing washers. Driven into back-up plates (Item 6), spaced 8 in. OC max.

4. **Supports** — Max spacing, 5 ft, 0-3/16 in. OC. Any of the following may be used as structural supports.

4a. **Purlins — (Not Shown)** — No. 16 MSG min cold rolled steel purlins or min K Series open web steel joists (40 ksi min yield strength).

4b. **Alternate Purlins — (Not Shown)** — Structural steel components (hot rolled beams, channel angles etc.) may be used with a min thickness, of the section receiving the panel clip fasteners, to be No. 12 MSG (33 ksi min yield strength).

4c. **Alternate Purlins — (Not Shown)** — Wood purlins or trusses may be used. Min thickness of the section receiving the panel clip fasteners to be 1-1/2 in.

5. **End-Lap Support — (Not Shown)** — For steel purlins min supporting width 2-1/2 in. Fabricated from No. 16 MSG min thick steel (40 ksi min yield strength). For wood purlins or trusses, support to be wood, 2-1/2 in. min supporting width, min thickness 1-1/2 in. Fastened to purlins with appropriate fasteners spaced max of 12 in. O.C.

6. **End-Lap Back-Up Plates — (Not Shown)** — Factory Installed — No. 16 MSG min thick coated steel, 1-1/4 in. wide, 4 in. long, factory located under the exterior face, at each minor rib, to receive the end lap screw fasteners. Max spacing 8 in. OC.

7. **Lateral Bracing (Not Shown)** — As required.

Refer to General Information, Roof Deck Constructions for items not evaluated.

**\* Indicates such products shall bear the UL or cUL Certification Mark for jurisdictions employing the UL or cUL Certification (such as Canada), respectively.**

Last Updated on 2013-03-11

---

[Questions?](#)

[Print this page](#)

[Terms of Use](#)

[Page Top](#)

© 2017 UL LLC

The appearance of a company's name or product in this database does not in itself assure that products so identified have been manufactured under UL's Follow-Up Service. Only those products bearing the UL Mark should be considered to be Certified and covered under UL's Follow-Up Service. Always look for the Mark on the product.

UL permits the reproduction of the material contained in the Online Certification Directory subject to the following conditions: 1. The Guide Information, Assemblies, Constructions, Designs, Systems, and/or Certifications (files) must be presented in their entirety and in a non-misleading manner, without any manipulation of the data (or drawings). 2. The statement "Reprinted from the Online Certifications Directory with permission from UL" must appear adjacent to the extracted material. In addition, the reprinted material must include a copyright notice in the following format: "© 2017 UL LLC".